







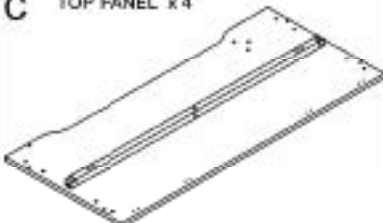
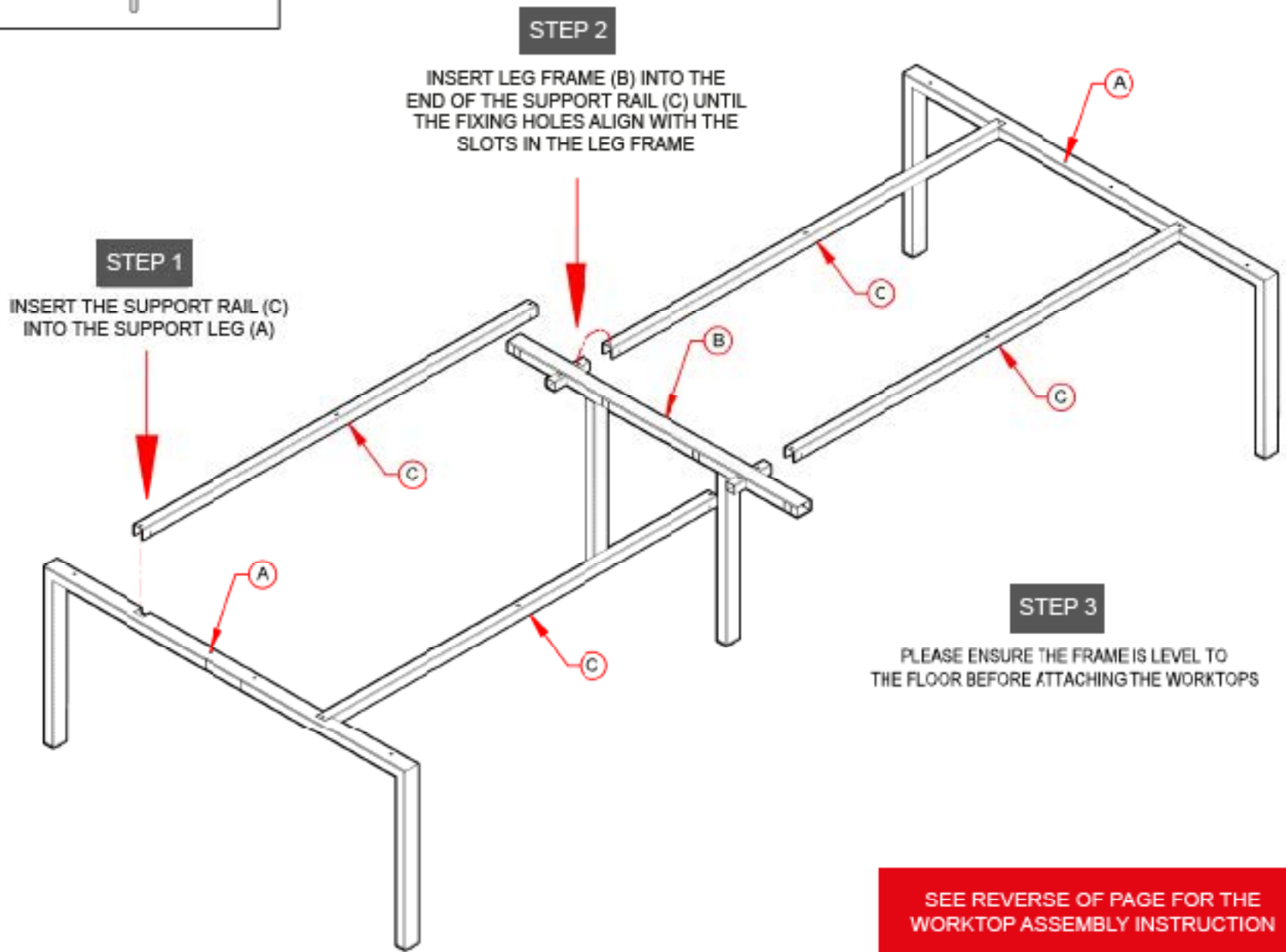

YOUR PARTS LIST	
A	STANDARD LEG FRAME x2 
B	INTERMEDIATE LEG FRAME x1 
C	TOP FANEL x4  <p>YOUR WORKTOP COMES WITH THE SUPPOR™ RAIL ATTACHED FOR SAFE DELIVERY, PLEASE REMOVE IT TO ALLOW THE ASSEMBLY TO BE COMPLETED CORRECTLY.</p>

TOOLS YOU WILL NEED
4mm ALLEN KEY 



SEE REVERSE OF PAGE FOR THE WORKTOP ASSEMBLY INSTRUCTION



YOUR PARTS LIST	
A	TOP CONNECTOR x 8  084836
B	M6 x 20 TORQ/HD SCREW x 8  K7002
C	M6 x 55 SOC/HEAD SCREW x 20  KB044
D	SPACER x 12  084388

TOOLS YOU WILL NEED
4mm ALLEN KEY 

VIEW SHOWING THE UNDERSIDE OF THE WORKTOP ASSEMBLY

STEP 1

LAY THE WORKTOPS ON THE FRAMEWORK AND ALIGN THE FIXING POINTS WITH THOSE IN THE FRAMEWORK, ATTACH AS ILLUSTRATED

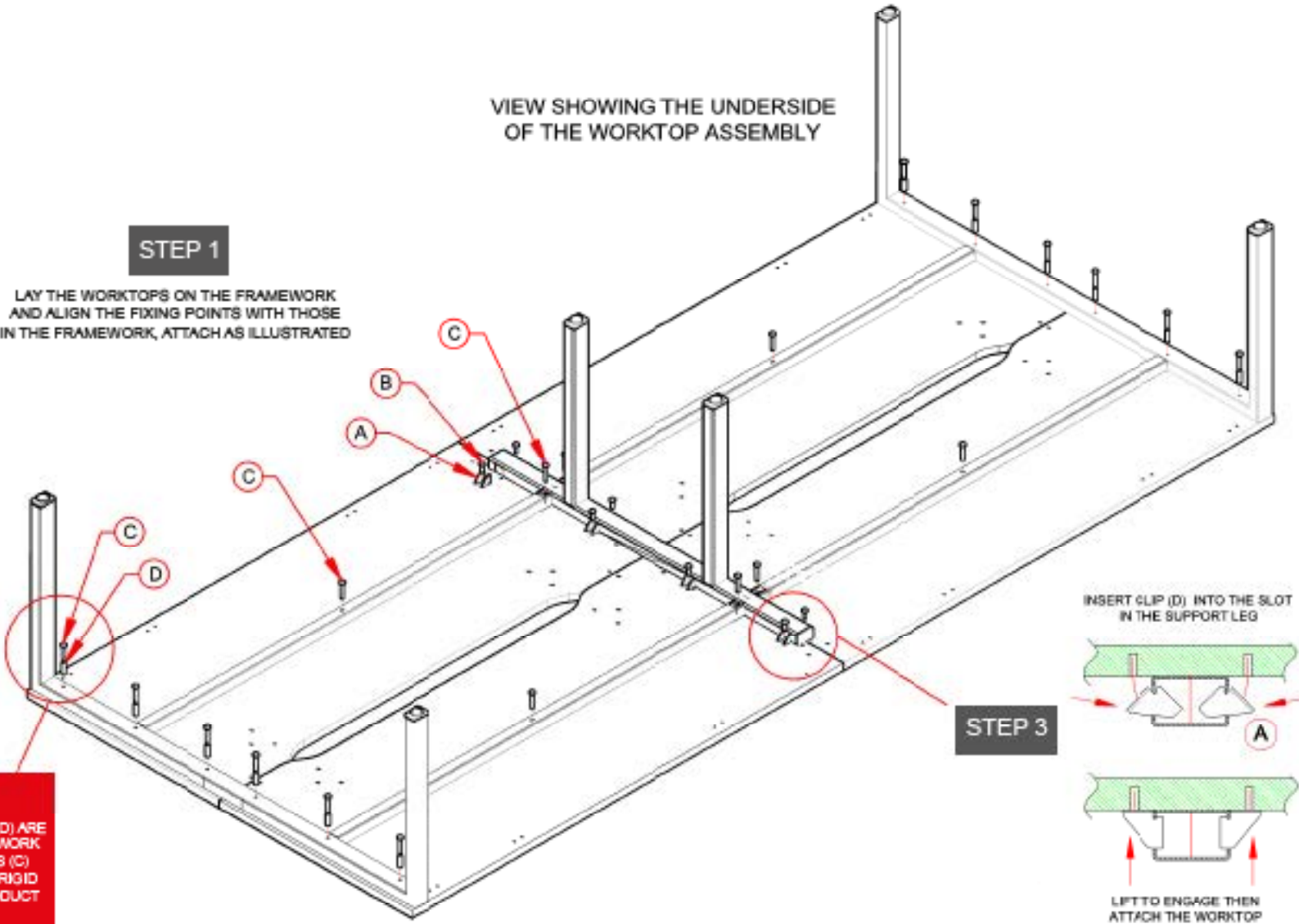

STEP 2

IMPORTANT NOTE

IT IS ESSENTIAL THAT THE SPACERS (D) ARE USED WHEN ATTACHING THE FRAMEWORK TO THE TOP PANEL WITH THE BOLTS (C) THIS ENSURES THE FRAMEWORK IS RIGID AND IN ACCORDANCE WITH THE PRODUCT WARRANTY SPECIFICATION



STEP 3

